



TOWN OF WALLINGFORD

Department of Engineering

45 South Main Street

Wallingford, CT 06492

Tel: (203)294-2035 Fax: (203)284-4012

EXCAVATION PERMIT APPLICATION FORM

Call Before You Dig
1.800.922.4455

Permit Number

Date _____ CBYD Ticket Number _____ Starting Date _____

Location _____

Excavation Size _____ Purpose _____

Applicant _____

Address _____ Telephone # _____

Contractor _____

Address _____ Telephone # _____

Emergency Contact Name _____

24-Hour Emergency Telephone # _____

Location sketch to show street, house, house number, driveway, curb type and location, sidewalk, utility poles, catch basins, manholes, North arrow and dimensional ties to excavated area.

Location Sketch (Check if separate plans have been submitted)

Note:

- 1) The undersigned hereby agrees to make an excavation, ditch, digging or otherwise alter, open or remove the surface of the above named street or highway under the jurisdiction of the Town of Wallingford in accordance with the "Ordinance Relating to Regulation of Excavation in Streets and Highways" in the Town of Wallingford.
- 2) Application for permit should be made forty-eight (48) hours before work commences. Prior to any excavation work, the Applicant shall contact the Department of Engineering and provide notification regarding the anticipated date for the start of work.

Applicant's Signature _____ Date _____



TOWN OF WALLINGFORD

Department of Engineering
45 South Main Street
Wallingford, CT 06492
Tel: (203)294-2035 Fax: (203)284-4012

REQUIREMENTS FOR EXCAVATION PERMITS

Originally Issued: March 19, 1992

Revised: February 3, 2005

The following is a list of items specified in the Town of Wallingford Excavation Ordinance, which must be furnished before any Excavation Permits can be issued. A copy of the Excavation Ordinance, which details requirements and obligations of the contractor, will be issued upon request.

1) Insurance and Bond

- a) Insurance: Evidence of public liability insurance of not less than:
 - \$2,000,000 aggregate
 - \$1,000,000 automobile
 - \$1,000,000 per incident
- b) Bond: Evidence of a performance bond in an amount of not less than \$5,000 or in greater amounts if required by the Department of Engineering, said bond shall be provided on the forms provided by the Department of Engineering.

BOND SCHEDULE

<u>Square Feet</u> <u>(to be excavated)</u>	<u>Bond Amount</u>
0 - 1,660	\$5,000
1,661 - 2,000	\$6,000
2,001 - 2,330	\$7,000
2,331 - 2,660	\$8,000
2,661 - 3,000	\$9,000
3,001 - 3,330	\$10,000
3,331 - 3,660	\$11,000
3,661 - 4,000	\$12,000
4,001 - 4,330	\$13,000
4,331 - 4,660	\$14,000
4,661 - 5,000	\$15,000
5,001 - 5,330	\$16,000
5,331 - 5,660	\$17,000
5,661 - 6,000	\$18,000
6,001 - 6,330	\$19,000
6,331 - 6,660	\$20,000
6,661 - 7,000	\$21,000
7,001 - 7,330	\$22,000
7,331 - 7,660	\$23,000
7,661 - 8,000	\$24,000
8,001 - 8,330	\$25,000
8,331 - 8,660	\$26,000
8,661 - 9,000	\$27,000
9,001 - 9,330	\$28,000
9,331 - 9,660	\$29,000
9,661 - 10,000	\$30,000

Requirements for Excavation Permits

- 2 -

2) Call Before You Dig

As required by the State of Connecticut Statutes, the Applicant must notify the Call Before Your Dig (CBYD) clearinghouse and furnish the Department of Engineering with a valid ticket number for each excavation prior to the issuance of any permits. Expired ticket numbers will not be accepted.

3) Backfill Material Certifications and Proposed Construction Procedures

The Department of Engineering will require detailed plans and specifications for the proposed excavation along with other engineering data prior to issuing any permits. Please refer to attached "NOTICE" and Trench and Pavement Repair drawing.

4) Fees

- a) \$5.00 for the first 200 square feet of excavated area or fraction thereof.
- b) \$5.00 for each additional 400 square feet of excavated area or fraction thereof.

FEE SCHEDULE

<u>Square Feet</u> <i>(to be excavated)</i>	<u>Fee Amount</u>
0 - 200	\$5
201 - 600	\$10
601 - 1,000	\$15
1,001 - 1,400	\$20
1,401 - 1,800	\$25
1,801 - 2,200	\$30
2,201 - 2,600	\$35
2,601 - 3,000	\$40
3,001 - 3,400	\$45
3,401 - 3,800	\$50
3,801 - 4,200	\$55
4,201 - 4,600	\$60
4,601 - 5,000	\$65
5,001 - 5,400	\$70
5,401 - 5,800	\$75
5,801 - 6,200	\$80
6,201 - 6,600	\$85
6,601 - 7,000	\$90
7,001 - 7,400	\$95
7,401 - 7,800	\$100
7,801 - 8,200	\$105
8,201 - 8,600	\$110
8,601 - 9,000	\$115
9,001 - 9,400	\$120
9,401 - 10,000	\$125

- 5)** All Applicants for Street Excavation Permits shall provide the required supplemental information as noted on the "Notice To Contractors", revised March 16, 2020.

All applications for Excavation Permits should be made at the Department of Engineering. A minimum of two (2) working days prior to the anticipated start of excavating, to allow sufficient time for review and processing.

SURETY BOND
Of
EXCAVATION CONTRACTOR

Bond No. _____

Know all Men by these Presents:

That We, _____ of _____ State of Connecticut, as Principal, and _____ of _____ State of Connecticut, as Surety, are holden and firmly bound jointly and severally unto the TOWN OF WALLINGFORD, a municipal corporation located in the State of Connecticut, in the penal sum of _____ Dollars (\$_____), to be paid to the said TOWN OF WALLINGFORD, its successors and assigns.

To the which payment, well and truly to be made and done, we the said Obligors do bind ourselves, and each of us, our heirs, executors, administrators, successors and assigns and each and every of them, for and in the whole, firmly by these presents:

THE CONDITIONS OF THIS OBLIGATION IS SUCH THAT

WHEREAS, the above named Principal has furnished evidence of Insurance and has been duly authorized by the TOWN OF WALLINGFORD in the State of Connecticut:

To make any excavation, ditch, digging, or otherwise alter, open or remove the surface of any street or highway being the entire width of any dedicated or otherwise legally acquired street or highway.

Now THEREFORE, if the said Principal shall well and truly perform the work for which said Authority is granted, and shall well and truly comply with all the provisions of the laws of the State of Connecticut and of the ordinances of the TOWN OF WALLINGFORD relating thereto; and shall well and truly comply with all of the rules and regulations of the TOWN OF WALLINGFORD and of the Engineering Department and/ or the Public Works Department of said Town, which are now or may hereafter be in force; and shall indemnify and save the TOWN OF WALLINGFORD and the Engineering Department and/ or the Public Works Department of said Town harmless in every respect from all losses, cost, liabilities, expenses, damages and suits whatever, arising out of or in connection with work done under such authorization, then this bond shall be void, otherwise: to remain in full force and effect for a period commencing _____ and ending when released by the Town Engineer or their authorized representative.

Signed with our hands and sealed with our seals, at _____ in the County of _____ on this _____ day of _____ A.D., 20_____.

{L.S.}

{L.S.}

STATE OF CONNECTICUT,
COUNTY OF NEW HAVEN.

Personally appeared _____ and _____ signer and sealer of the foregoing instrument, and acknowledge the same to be their free act and deed, at Wallingford, on this _____ day of _____ A.D., 20_____.

NOTICE TO CONTRACTORS

EXCAVATIONS WITHIN THE PUBLIC RIGHT-OF-WAY

- 1) Application forms for all non-emergency work must be submitted a minimum of five (5) working days in advance of the scheduled start-date,
- 2) Incomplete Applications will not be processed and will be returned to the Applicant,
- 3) Bonds and Insurance certificates MUST be name of the Applicant or Contractor, whoever is performing the work and said certificates MUST be current or the Application will not be processed,
- 4) The required manpower / equipment list, material certifications and proposed sequence of construction MUST be completed and submitted with the Application,
- 5) The Applicant / Contractor shall designate the "official" project representative, who will be in charge of the on-site work. Contact name and a reachable telephone number MUST be provided,
- 6) At the time the Excavation Permit is issued, the Applicant MUST sign and date the form, acknowledging acceptance of any specific Conditions of Approval. A copy of the signed form will be kept by the Department of Engineering,
- 7) The Applicant / Contractor MUST notify the Department of Engineering (by phone or fax) a minimum of 24 hours in advance of the start of any excavation in the Public Right-of-Way,
- 8) The Excavation Permit, with all attachments and any specific Conditions of Approval MUST be on the job site with the designated project representative at all times when there is active work,
- 9) The Applicant / Contractor MUST notify the Wallingford Police Department Dispatch Center (203-294-2800) when the permitted work will alter or otherwise impact normal traffic operations (ie; alternating traffic flows thru the work zone, etc),
- 10) Road closures are NOT permitted, unless a separate "Road Closure Permit" has been jointly issued by the Wallingford Police Department and Department of Engineering, and
- 11) Any individual, firm, company or business entity determined to be in violation of these Conditions shall be subject to the enforcement provision of the Ordinance, as well as the immediate revocation of the subject permit, the suspension on the issuance of any new Excavation Permits, the cost of any repairs or remedial work and other such actions as may be determined by the Town to insure, protect and maintain the integrity of the Town's municipal Right-of-Way.

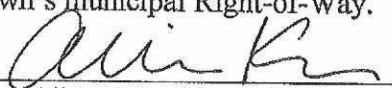

Alison Kapushinski, P.E.
Town Engineer



Tiffany Shipman
Assistant Town Engineer

Issue Date: 8/16/ 2020



TOWN OF WALLINGFORD

Department of Engineering

45 South Main Street

Wallingford, CT 06492

Tel: (203)294-2035 Fax: (203)284-4012

Street Excavation Permit Application APPLICATION REVIEW FORM

(To be Completed by Department of Engineering)

- Completed Excavation Permit Application Form
- Surety Bond (minimum of \$5,000)
- Current Insurance Certificate
- Valid CBYD Ticket Number (no older than 30 days)
- 24-hour Emergency Contact (name and phone number)
- Plan
- Narrative
- Material Certification
- Anticipated Start Date _____

Contractor: _____

Location of Work: _____

Applicants Name: _____

Date: _____

TEMPORARY PAVEMENT REPAIRS IN ACCORDANCE WITH THE TOWN EXCAVATION ORDINANCE & THE REQUIREMENTS OF THE TOWN ENGINEER. THE THICKNESS OF THE TEMPORARY PAVEMENT MAY BE INCREASED IF THE ROAD WILL BE MILLED AND OVERLAYED IN LIEU OF PERMANENT PAVEMENT REPAIRS.

PERMANENT PAVEMENT RESTORATION IN ACCORDANCE WITH THE TOWN EXCAVATION ORDINANCE & THE REQUIREMENTS OF THE TOWN ENGINEER.

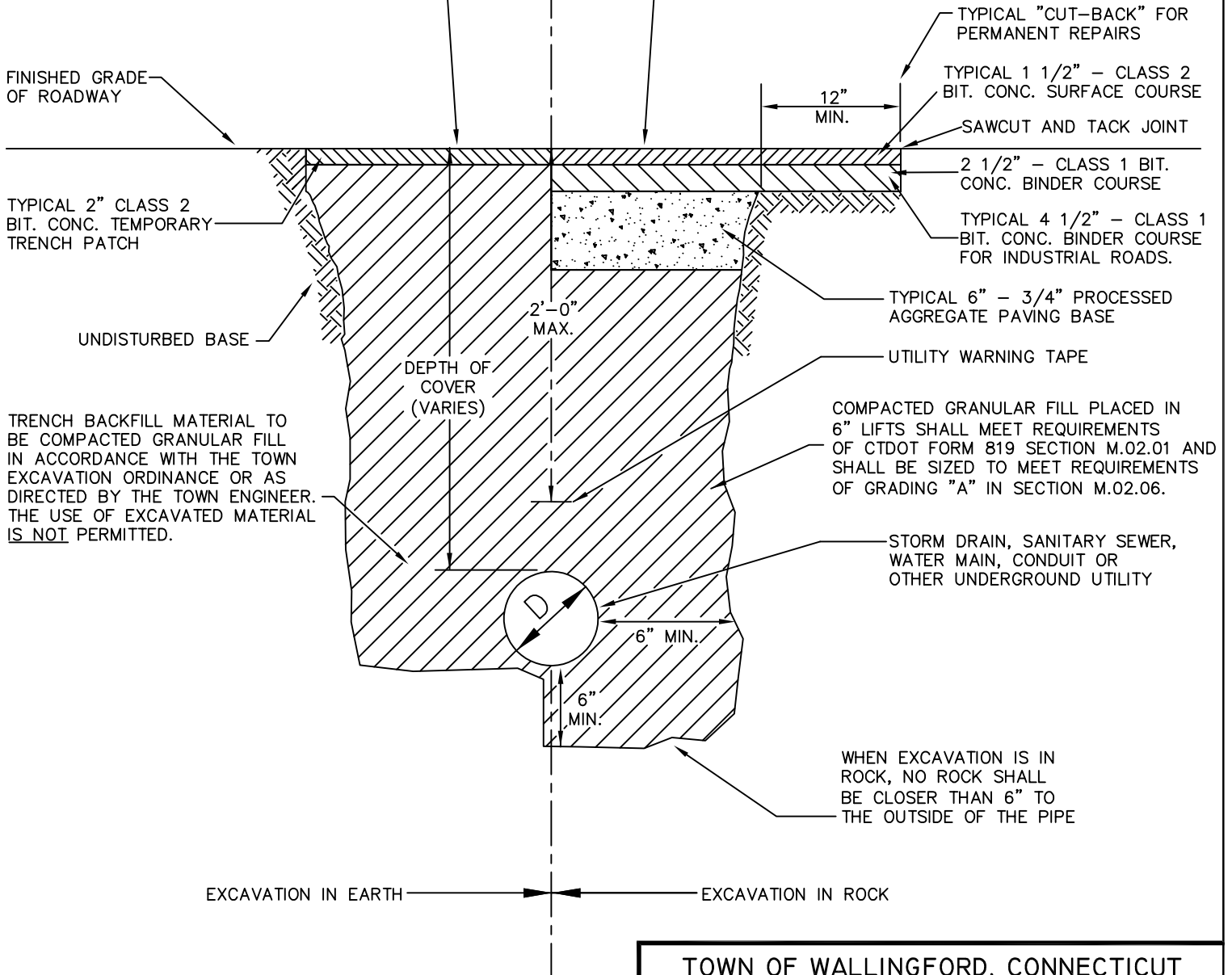

TRENCH BACKFILL MATERIAL TO BE COMPACTED GRANULAR FILL IN ACCORDANCE WITH THE TOWN EXCAVATION ORDINANCE OR AS DIRECTED BY THE TOWN ENGINEER. THE USE OF EXCAVATED MATERIAL IS NOT PERMITTED.

COMPACTED GRANULAR FILL PLACED IN 6" LIFTS SHALL MEET REQUIREMENTS OF CTDOT FORM 819 SECTION M.02.01 AND SHALL BE SIZED TO MEET REQUIREMENTS OF GRADING "A" IN SECTION M.02.06.

STORM DRAIN, SANITARY SEWER, WATER MAIN, CONDUIT OR OTHER UNDERGROUND UTILITY

WHEN EXCAVATION IS IN ROCK, NO ROCK SHALL BE CLOSER THAN 6" TO THE OUTSIDE OF THE PIPE

EXCAVATION IN EARTH EXCAVATION IN ROCK

<p>TOWN OF WALLINGFORD, CONNECTICUT DEPARTMENT OF ENGINEERING</p>				
<p>TYPICAL TRENCH DETAIL FOR TEMPORARY & PERMANENT PAVEMENT REPAIRS</p>				
SCALE:	DATE:	DRAWN BY:	IDENT. NO.:	SHEET NO.:
N.T.S.	8/12/24	D.A.S.	ENG.	1 of 1

NOTE:
ALL TRENCHING, EXCAVATION & MAINTENANCE OF THE TRAFFIC SHALL BE IN STRICT ACCORDANCE WITH ALL APPLICABLE FEDERAL, STATE & LOCAL REGULATIONS. THE EXCAVATOR SHALL USE TRENCH SUPPORT AND BRACING AS REQUIRED BY O.S.H.A. REGULATIONS TO ENSURE THE STABILITY AND SAFETY OF ALL TRENCHES.

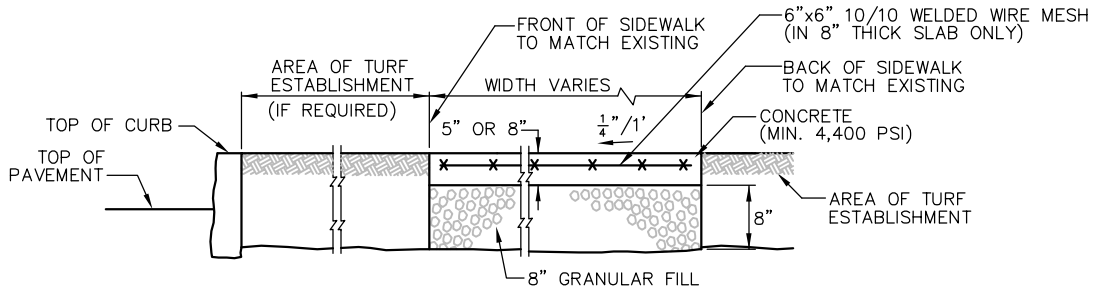

SECTION B-B

SCALE: NOT TO SCALE

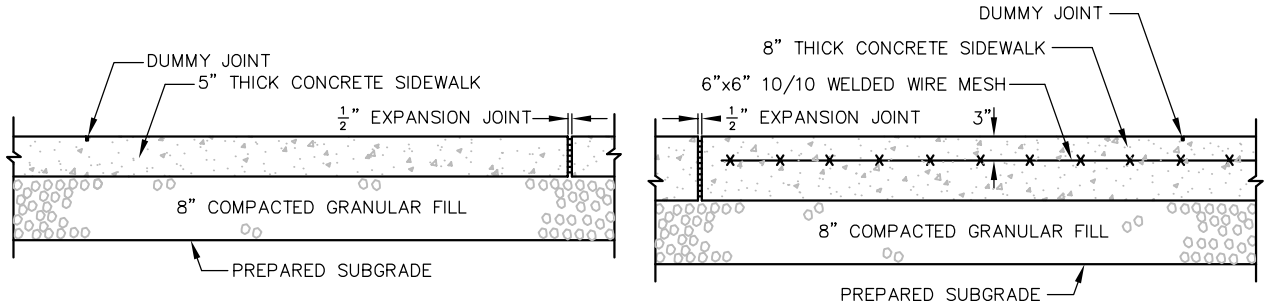

5\"/>

8\"/>

SECTION A-A

SCALE $\frac{1}{2}''=1'-0''$

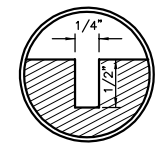

DUMMY JOINT
HALF SIZE

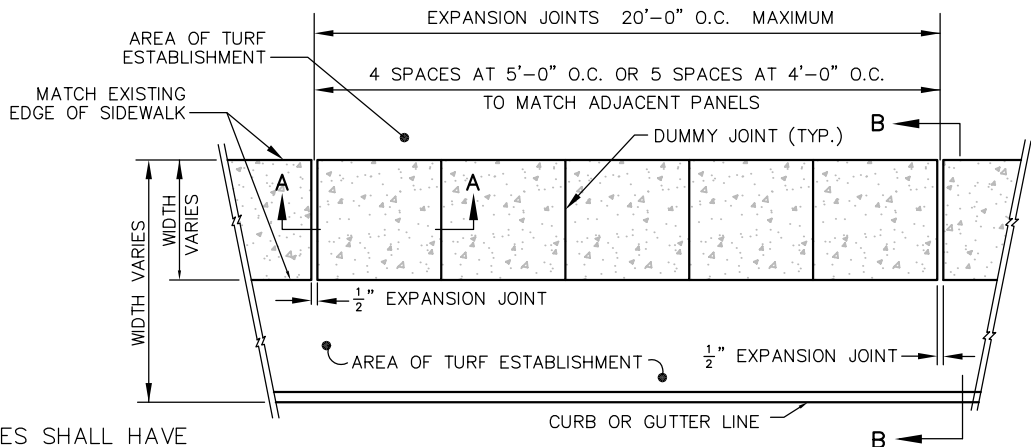

PLAN VIEW

SCALE $\frac{1}{8}''=1'-0''$

NOTES:

1. ALL EXPOSED EDGES SHALL HAVE 1/4" CHAMFER AND BE 'FRAMED'.
2. CONCRETE SHALL HAVE MIN. COMPRESSIVE STRENGTH OF 4,400 PSI.
3. CONCRETE SIDEWALKS THROUGH DRIVEWAYS SHALL BE 8" THICK WITH REINFORCING AS SHOWN. ALL OTHER WALKS ARE 5" THICK.
4. GRANULAR FILL SHALL MEET REQUIREMENTS OF CTDOT FORM 819 SECTION M.02.01 AND SHALL BE SIZED TO MEET REQUIREMENTS OF GRADING "A" IN SECTION M.02.06.
5. THE CONTRACTOR SHALL RESTORE ALL DISTURBED AREAS.

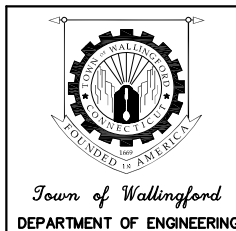

STANDARD DETAIL

5-INCH AND 8-INCH THICK CONCRETE SIDEWALK INSTALLATION

ENGINEERING DEPARTMENT
TOWN OF WALLINGFORD

SCALE: AS NOTED

DATE: AUG. 2024

SHEET: D-2

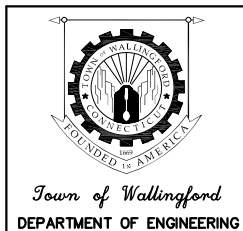
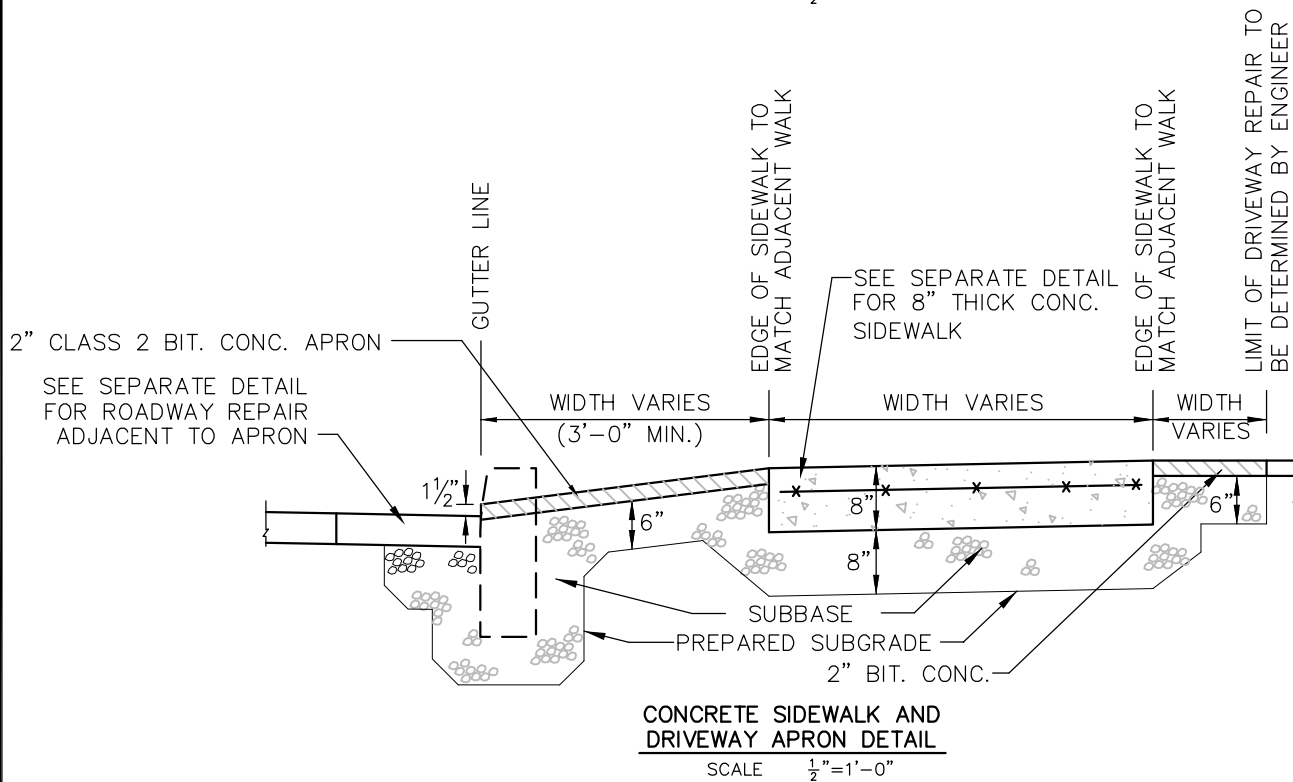
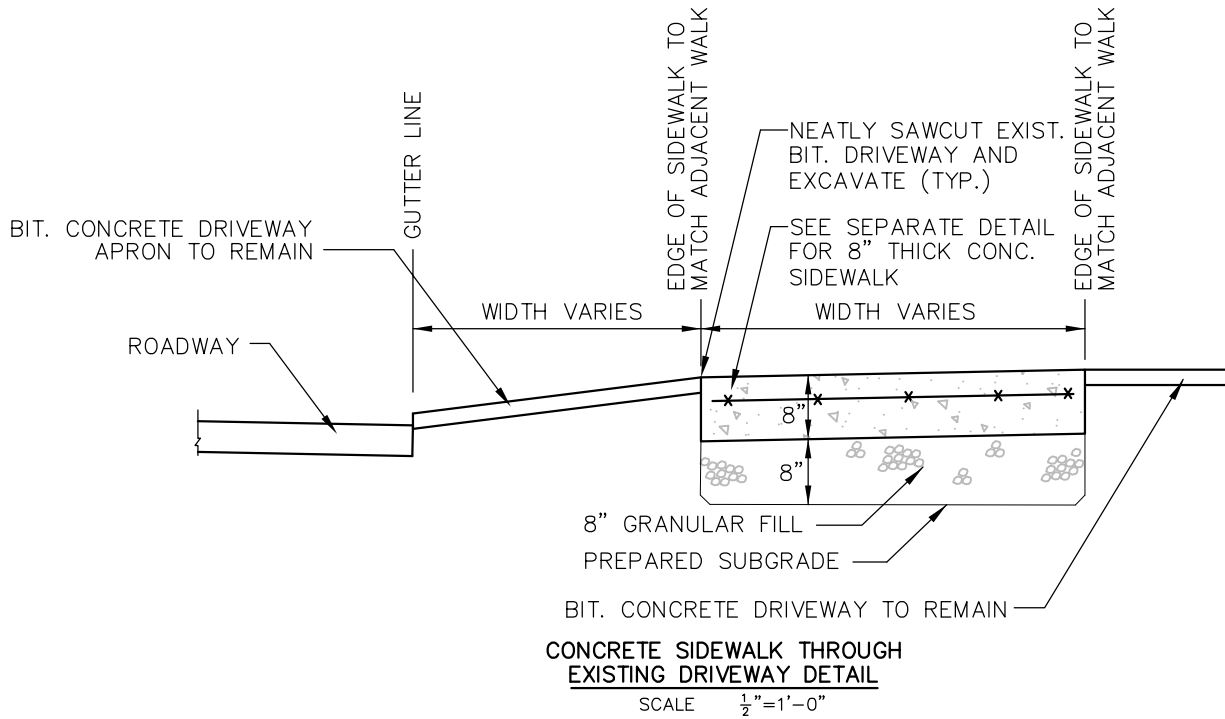

STANDARD DETAIL

CONCRETE SIDEWALK AT BITUMINOUS CONCRETE DRIVEWAY

ENGINEERING DEPARTMENT
TOWN OF WALLINGFORD

SCALE: AS NOTED

DATE: AUG. 2024

SHEET: D-3

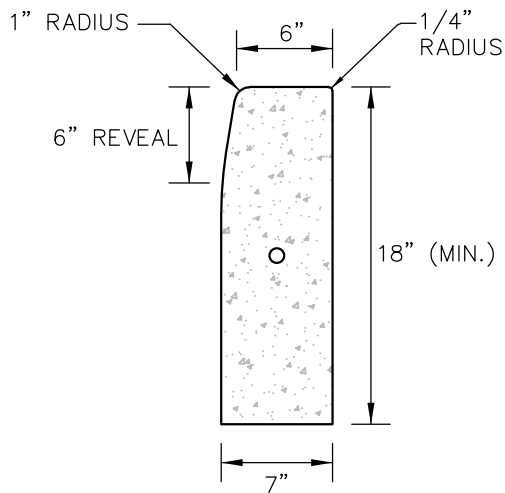

**PRE-CAST
CONCRETE CURB SECTION**
SCALE 1"=1'-0"

SEE SEPARATE DETAIL
FOR ROADWAY REPAIR
ADJACENT TO CURB

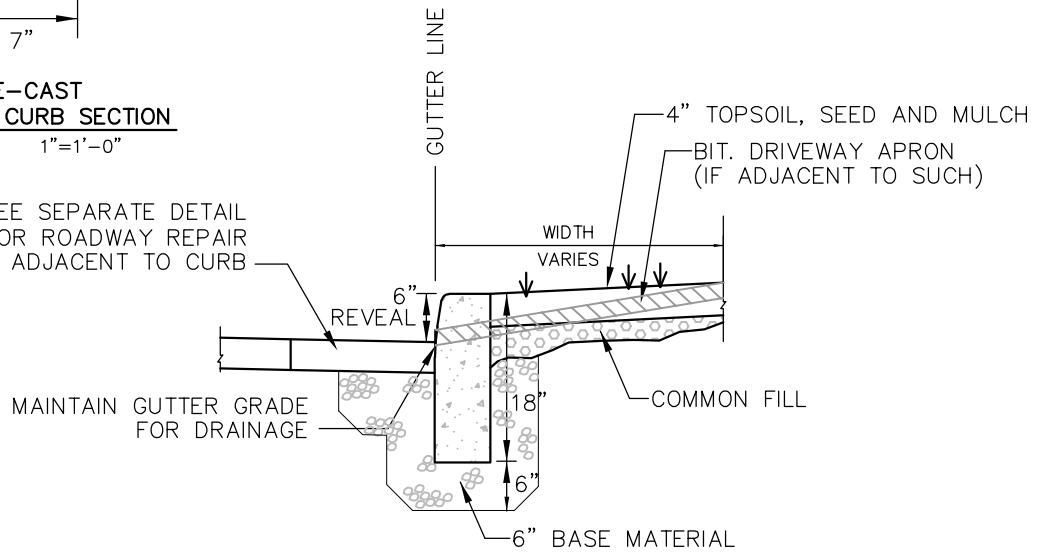

**CONCRETE CURB
INSTALLATION DETAIL**
SCALE 1/2"=1'-0"

NOTES FOR CONCRETE CURB:

1. CONSTRUCTION JOINTS SHALL BE SPACED APPROXIMATELY AT 10 FOOT INTERVALS, BUT NOT LESS THAN 6 FOOT INTERVALS.
2. JOINTS SHALL MATCH THOSE OF ADJACENT SIDEWALK.
3. EXPANSION JOINTS SHALL BE SPACED AT 20 FOOT INTERVALS. USE 1/2" EXPANSION JOINT FILLER.
4. PRE-CAST CURBS SHALL BE OF 5,000 PSI CONCRETE AND MAY BE CAST BY MANUFACTURER WITH OPTIONAL LIFTING & DOWEL BAR HOLES.
5. BASE MATERIAL SHALL CONFORM TO CTDOT FORM 819 SECTION M.02.01, M.02.02 OR M.05.01.

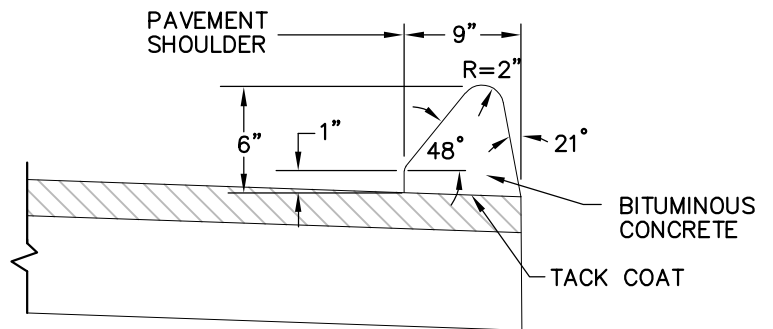

BITUMINOUS CONCRETE LIP CURBING

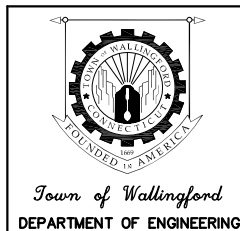

STANDARD DETAIL

**CONCRETE CURB AND
BITUMINOUS CONCRETE CURB**

ENGINEERING DEPARTMENT
TOWN OF WALLINGFORD

SCALE: AS NOTED

DATE: AUG. 2024

SHEET: D-4